

Joint Multi-layer Survivability Techniques for IP-over-Elastic Optical Networks [Invited]

P. Papanikolaou, K. Christodouloupoulos, and E. Varvarigos

Abstract— The traffic in metro and core networks is forecasted to grow in volume but also in dynamicity. Network operators dimension their optical networks and their IP edges for the expected traffic peak, and also reserve additional resources for the required survivability level. The latter is typically done by protection mechanisms at the optical or IP layer only. Multi-layer proactive restoration techniques can reduce the cost by enabling resource sharing while providing the same level of survivability. In this work we formulate the multi-layer survivability problem for an IP over elastic optical network (EON) and present ILP formulations to solve it, targeting two survivability levels: (i) single optical link and (ii) single optical link or optical and IP node failure. The proposed ILP algorithms are also distinguished with respect to their failure consideration point: (i) sequential, where we assume that the network is dimensioned for normal operation and then re-dimensioned to be resilient, and (ii) joint, where the network is dimensioned in a single step, considering normal and all single failures operation. We exploit the proactive (a priori provisioning) restoration concept to achieve sharing of the backup resources among different failure states. The proposed multi-layer techniques enable even higher efficiency, exploiting the IP grooming capabilities to enable the sharing of backup resources for a specific failure state but also the sharing of primary and backup resources. Compared to traditional single layer protection approaches, the proposed joint multi-layer techniques were shown to yield significant cost savings.

Index Terms— elastic optical networks; ILP model; multi-layer network planning; multi-layer resilience; protection; restoration.

I. INTRODUCTION

The Internet is continuously transforming our working and lifestyle reality. Emerging services such as Video on Demand, tele-conferencing, mobile broadband and cloud

applications cause tremendous pressure on network infrastructures. Apart from increased traffic volume, traffic dynamicity is becoming a key challenge. In order to meet such requirements telecom operators are facing the problem of dimensioning their networks for the expected huge IP traffic volumes while keeping or even reducing the prices.

Optical metro/core transport networks are typically over-dimensioned for IP traffic peaks. Traditionally such networks are based on WDM technology, which however provides rigid and rather coarse granularity, adding inefficiencies when matching the required demands to the supported rates. Elastic optical networks (EON) that combine flex-grid switches and flexible (tunable) transponders (also referred to as bandwidth variable transponders - BVT) are a promising solution to increase optical network efficiency and reduce the cost [1].

A typical requirement when designing an optical transport network is that it is survivable to a certain level (type) of failures. Providing resilience can be done in two ways: (i) sequential primary and backup selection, where the network is planned for normal operation and then it is re-dimensioned to provide resilience, (ii) joint primary and backup selection: where the network is designed for both normal and operation under failures. In the first case, the resiliency problem is treated as an “afterthought” to the main provisioning problem, while in the latter (and more efficient) case it is treated “simultaneously” with the main provisioning problem. Providing resiliency increases the cost of the already over-provisioned optical network. Intuitively, the sequential approach finds the optimal primary paths, fixes those and then finds the secondary paths avoiding the primary one, resulting in most cases in suboptimal secondary path. The joint approach finds in a single step both the optimal primary-secondary paths, i.e. paths with balanced lengths – optimal “cycles”. As so, the joint approach is more complex and more cost efficient than the sequential approach.

Although there is a trend to migrate toward an IP/MPLS over a WDM/EON architecture, there is still a separation of the IP and optical management layers, which leads to highly redundant and uncoordinated survivability schemes. *IP layer only* and *optical layer only* resilience techniques present many limitations and result in inefficient use of resources and higher network costs [2].

Optical layer only resilience techniques are typically divided in two broad categories, protection and restoration.

Manuscript received June 15, 2016; revised September 22 2016; (Doc. ID 268104)

P. Papanikolaou (e-mail: ppapanikola@central.ntua.gr), K. Christodouloupoulos, and E. Varvarigos are with the School of Electrical and Computer Engineering, National Technical University of Athens, GR15780, Zografou, Greece.

Protection requires extra equipment and allocates resource for backup purposes, which are disjoint from the primary ones. There are several different protection schemes: 1+1 where the traffic is split (50 % each) between primary and backup resources, 1:1 where only primary resources are used under normal operation, while the backup are used when a failure occurs, $N:M$ where N backup resources are shared for recovery purposes by up to M primary resources. Backup resources in protection schemes are pre-defined and reserved, and so recovery is done very fast. Restoration targets to reduce the cost by enabling the sharing of resources, sacrificing in some cases the recovery speed. Restoration can be reactive, in which case the backup configuration is calculated upon a failure, or proactive, where the backup configurations are pre-calculated for a set of failures and corresponding resources are reserved. Proactive restoration can ensure the resilience levels of protection, the key difference being that in restoration the backup configuration (backup paths) are not pre-established and pre-determined as in protection. Proactive restoration increases the recovery speed over reactive restoration, while at the same time it also increases the efficiency through the sharing of resources. Backup resources can be shared for different failures, as long as these are independent (belong to different shared risk groups).

A failure at an optical link (the most common type of failure) or at a transit (without add/drop capabilities) optical node can be recovered at the optical layer, i.e. with optical layer only protection or restoration. Optical node with add/drop capabilities (reconfigurable add drop multiplexer - ROADM) or transponder failures, or any IP router failures need to be recovered from the IP layer.

Considering *only IP layer* resilience, we can again have the notion of protection and restoration. A common protection (similar to optical only 1+1 protection) practice used by operators is to build two variants of the network that mutually protect each other (referred to as the *dual-plane protection*) [3]. Following this practice, the IP layer carries out the protection function, switching between the two network variants when it senses a problem at the IP layer, without any information exchange between the two layers. This practice yields bad utilization of both router interfaces as well as optical transponders and switches and requires double equipment of the primary network.

To address the inefficiencies of single-layer resilience techniques, recent works have started to examine various ways to co-ordinate the operations of both the IP and optical layers. These multi-layer resilience techniques restore the affected traffic using the appropriate resources from each layer so as reduce the total network cost. They exploit the grooming capabilities of the IP layer and virtual link establishment (optical lightpaths) enabling the sharing of primary and backup resources to reduce the spare resources needed. Adding to that the restoration concept, where resources can be shared among different failure cases, we can obtain significant cost and energy savings.

In this paper, we focus on the multi-layer resilience of an IP over EON. Our objective is to deploy the minimum amount of network resources so that we are able to survive (i) any single link or (ii) any single link and (optical or IP) node failure. The ILP formulations model all the failure

cases and calculates for each the restoration network configuration, re-using resources among the different failures and the primary resources freed in each failure case. The ILP algorithms consider failure at two points: (i) sequentially, where we assume that the network is dimensioned for normal operation by choosing the primary paths and then on top of that (“as an afterthought”) we re-dimension the network to provide resilience by selecting the backup path, and (ii) jointly, where the network is dimensioned in a single step and primary and backup paths are jointly (“simultaneously”) selected, considering normal and all single failures operation.

Our results indicate that significant cost savings can be obtained when we dimension the IP over EON considering multi-layer resilience, as opposed to the case where the traffic is restored at the IP layer or at the optical layer only. We also verified that dimensioning jointly the network for normal and failure operation leads to a more efficient resources usage by allowing maximal sharing of the primary and backup resources.

The rest of the paper is organized as follows. Section II presents the related work, while Section III describes the multi-layer survivability problem. Section IV describes the proposed multi-layer resilience techniques, while in Section V their performance is evaluated. Finally, our conclusions are given in Section VI.

II. RELATED WORK

The survivability of WDM and Elastic Optical Networks (EON) has been an active and fruitful research subject in the past few years. Increasingly more efforts focus on the design of algorithms whose goal is to grant the same survivability level with the lowest possible cost. We classify these survivability algorithms into two subcategories: (i) single layer [4]-[7] and (ii) multi-layer [8]-[14].

Approaches for single layer only survivability algorithms include protection and restoration techniques. In [4] the authors propose a hybrid protection-restoration mechanism, called threshold-based selective link restoration, which attempts to improve the overall restoration efficiency provided by link restoration. They also consider two policies regarding the way the used threshold is determined, per-link load or per-link reliability. The restoration problem for optical networks is studied in [5], where the authors propose a flooding-based recovery scheme for optically transparent networks that provides 100% recovery from all single link and node failures in a capacity-efficient manner. A dynamic restoration scheme for EONs that is based on Software Defined Networking (SDN) technology was presented in [6]. The proposed scheme exploits centralized path computation and node configuration to avoid contentions during the recovery procedure with the objective being the minimization of recovery time. The restoration problem of EONs has also been treated in [7], where the authors investigate the utilization of sliceability during provisioning and restoration in elastic optical networks, and propose a scheme to exploit the possibility of establishing/recovering an optical connection as a single superchannel or as a number of independent subcarriers.

The survivability of multi-layer networks has also

received considerable attention by both the research community and the operators. According to today's traditional approach, the IP layer is responsible for failure recovery when survivability against transponders, ingress optical switches and IP equipment is considered. Such approach, however, leads to an enormous over-provisioning of IP interfaces, which are largely underutilized, with a consequently high CapEx and decreased profitability (ROI). The authors in [8] compared the current dual protection schemes with the multi-layer restoration in a realistic network scenario and demonstrated significant cost savings. In order to achieve such cost savings and minimize the over-dimensioning of IP nodes, the authors in [9] developed mathematical programming models for the joint multi-layer approach that provides survivability against optical links, IP nodes, and opto-electronic port failures through an orchestrated interlayer recovery scheme. Exploiting the advanced optical layer capabilities and multi-layer control, the authors in [10] presented the multi-layer shared backup router (MLSBR) concept. The idea behind the MLSBR is based on having extra shared backup routers to restore the traffic in case of a failure of an IP router. Furthermore, the authors in [11] investigate the impact of IP layer routing policies on multi-layer network design, while in [12] an advanced multi-layer resilience scheme with optical restoration for IP over DWDM core networks is proposed. Authors in [13] presented a multi-layer latency-aware planning algorithm to dimension IP/OSPF-over-WDM networks with single and multi-layer recovery schemes, while in [14] a multi-layer restoration mechanism for IP over elastic networks is proposed, which offloads best effort traffic to the optical layer, and guarantees fast recovery for high priority traffic at IP layer.

Even though multi-layer restoration of EON is a topic that has been extensively researched, showing that the joint consideration of both layers yields significant gains, there is no formal description and optimal solution (e.g. given by an ILP formulation) to the joint primary and backup path selection problem, to the best of our knowledge. The main contributions that distinguish this work are the following. Firstly, the proposed survivability techniques provide an optimal solution for an IP over optical network through joint (crosslayer) optimization over the IP and optical layer, in contrast to most previous algorithms that provide pure protection or restoration solutions at each layer (IP and optical) of a multi-layer IP over optical network. Secondly, the joint (simultaneous) selection of primary and backup paths dimension the network for normal operation and fault tolerance at the same step to achieve maximal sharing, so that the cost is minimized. In other words the term "joint" optimization in our work refers to both (i) crosslayer and (ii) simultaneous primary-backup optimization. Thirdly, the sequential failure consideration algorithms can be used on top of any dimensioned network for normal operation to provide the required survivability level. Finally, the proposed algorithms are quite general and can be used to address survivability from optical link or IP/optical node failures in fixed-grid or flex-grid optical networks, with tunable or not transponders.

III. PROBLEM STATEMENT

In this section we describe the architecture of the IP over elastic optical network (EON) and the multi-layer survivability problem.

A. IP-over-Elastic Optical Network Architecture

We assume an EON domain that consists of optical switches and fiber links. The optical switches function as Reconfigurable Optical Add Drop Multiplexers (ROADMs) employing the flex-grid technology, supporting optical connections (lightpaths) of one or more contiguous 12.5 GHz spectrum slots. Note that the mechanisms to be proposed will also be valid for fixed-grid WDM networks (50 GHz wavelengths), which are a special and simpler case of EONs. At each optical switch, none, one or more IP/MPLS routers are connected, which comprise the edges of the optical domain. An IP/MPLS router is connected to the ROADMs via a grey or a colored transceiver. In the case of a short reach gray transceiver, flexible transponders (also referred to as Bandwidth Variable Transponders – BVTs) are plugged to the ROADMs to transform the client signal for optical long-haul transmission. Alternatively, flexible colored transceivers could be plugged to IP/MPLS routers ports, generating signal that directly enters the optical domain. Since the two above alternatives are almost equivalent, in terms of cost and functionality, we will focus on the former (transponder) case.

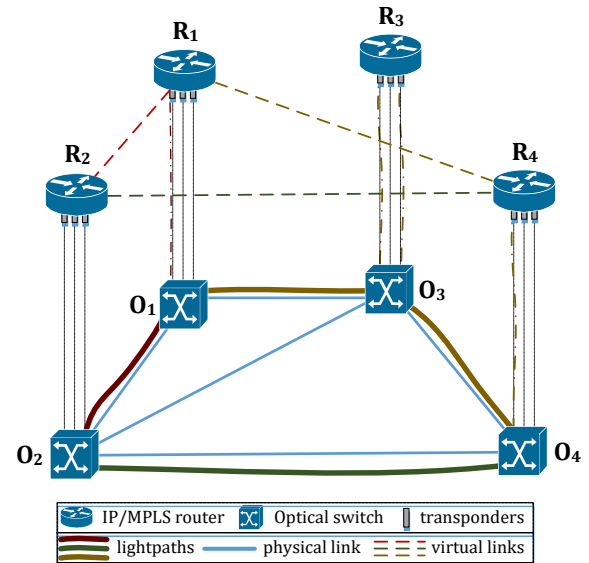

Fig. 1. Architecture of IP over elastic optical network

The transponder, functioning as a transmitter, transforms the electrical packets coming from the IP source router to the optical domain (E/O conversion) and then the traffic entering the ROADMs is routed over the optical network in all-optical connections (lightpaths). We assume that a number of transmission parameters of the flexible transponders are under our control (which is the reason the transponder is called "flexible"), affecting the rate and reach at which they can transmit. At the destination of a lightpath, the signal is converted back to electrical at the transponder that functions as an optical receiver (O/E conversion). The packets are then forwarded and handled

by the corresponding IP/MPLS router. This IP/MPLS router can be: (i) the final destination of some packets in the domain, in which case these packets will be forwarded further towards their final destination through other domains or lower hierarchy level networks attached to that router, or (ii) an intermediate hop, in which case the related packets will re-enter the optical network to be eventually forwarded to their domain destination (Fig. 1). We assume that lightpaths are associated bidirectional and thus in the above description an opposite directed lightpath is also installed, and the transponders act simultaneously as transmitters and receivers. An associated bidirectional path supports traffic in both directions and is constructed from a pair of unidirectional paths. The forward and backward directions may follow or not the same routes (note that following different routes does not reduce the network cost) and are monitored, and protected independently. Also, note that packet processing is only performed electronically, and in particular at the IP/MPLS routers, while optical switches function as transparent pipes between IP/MPLS router end-points.

B. Multi-layer Network Survivability

Network planning can be performed keeping IP and optical layer independence, following an overlay approach. In this case, recovery mechanisms are kept within each layer and hence no interlayer recovery mechanisms are required. A failure at an optical link (the most common type of failure) or a transit (without add/drop capabilities) optical node can be recovered only at the optical layer, e.g. with protection of restoration techniques. Optical node with add/drop capabilities (ROADMs) or transponder failures need to be recovered from the IP layer, along with any IP/MPLS router failures. So a certain redundancy level must be foreseen at the IP layer to prevent outages from any type of failure.

To the other end, IP only protection can recover from any type of failure, both optical and IP. *Dual plane* is a common IP only protection technique used by some network operators. In a dual plane design, two network variants are built, which mutually protect each other, providing redundancy against all single (optical and IP) equipment failures. The traffic is split in the two planes, each carrying 50% of the traffic, but each plane is dimensioned to carry 100% of the traffic, so in the case of a failure the other plane can absorb the affected traffic. The redundant IP routers are located either in different buildings, or in different fire segments of a single central office. Beneath the routers are two independent elastic (or fixed-grid WDM) networks. Fiber links are considered as mutually disjoint and the same applies to the optical nodes. Traffic is split over the two planes using Equal Cost Multipath (ECMP), which allows a faster switchover by IP/MPLS Fast-Reroute (FRR) in case of failures (up to 50 ms). The recovery is actually performed by the routers at the lower IP level. Fig. 2 demonstrates the dual plane approach and the protection actions for IP/optical node and optical link failure.

Building the two network planes is possible by replicating a network dimensioned for normal operation. The network dimensioning can be done using any multi-layer planning algorithm. In this work for comparison purposes we used the joint multi-layer EON planning

algorithm of [16], doubling the calculated resources, both optical (transponders, OXCs and EDFAs) and IP (linecards, LCCs, FCCs and fabric cards).

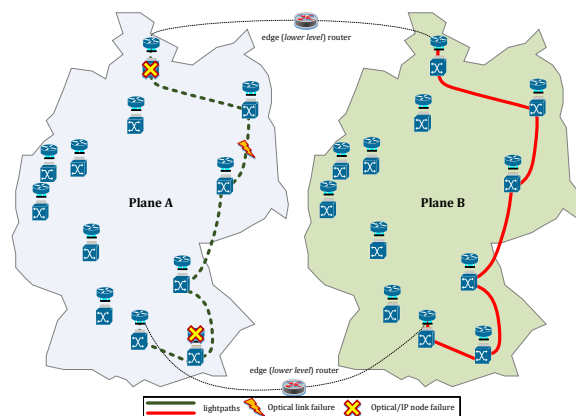

Fig. 2. Dual plane approach: single optical link / (IP & optical) node failure recovery

Obviously, the above discussed single-level survivability solutions are far from achieving an optimal overall cost. On the contrary, sophisticated survivability mechanisms that are able to trigger co-ordinated actions across the two layers can be applied to avoid equipment duplications. To this end we present four multi-layer survivability algorithms characterized by different levels of (i) survivability and (ii) failure consideration. The different levels of survivability are defined with respect to the covered failures, which contain either (i) single optical link, or (ii) single link and IP and optical node failures. So, the first level provides survivability that we obtain by optical layer only protection techniques (e.g. 1+1, 1:1), while the second level provides survivability that we obtain by IP layer only protection techniques (e.g. dual plane).

The different failure consideration levels are defined with respect to the degree to which information from the failure analysis is considered in the dimensioning of the multi-layer network. In particular, we distinguish between two levels: (i) sequential primary-backup survivability on top of a planned network, (ii) joint primary-backup multi-layer survivable planning. The former, sequential, failure consideration case facilitates the solution of the resiliency problem when treated as an “afterthought” to the primary provisioning problem. It assumes that we are given as input a dimensioned network (both IP & optical layers) for normal operation (this can be considered as step zero). Then, on top of that we provide resilience in two steps: in the first step we perform a failure analysis to define which lightpaths and end-to-end IP connections (i.e., IP tunnels over the lightpaths) are affected by each failure. In the second step, we re-dimension the network to restore the identified lightpaths, re-using either already installed equipment or adding new in both layers. The latter, joint primary-backup, failure consideration case adopts a more holistic multi-layer methodology by jointly (in a single step) selecting the primary and backup connections (both IP and optical layers of the network), considering normal and all single failures operation. It is important to note that the additional (backup) resources (both IP and optical), are not dedicated to addressing any specific failure even though they are

provisioned (reserved). So they are shared among all possible failures, assuming co-ordinated restoration operation of the two layers. Note that in order to keep the control plane overhead low, traffic unaffected by a failure is not rerouted. Restoration configurations for all failure cases are pre-calculated, to provide the given survivability level (see above for the two levels) as the related dedicated protection schemes.

IV. MULTI-LAYER SURVIVABILITY TECHNIQUES

We assume that the network is represented by a graph $\mathcal{G}(V,D)$, with V being the set of nodes and L the set of bidirectional fiber links connecting two locations. The nodes of the the graph correspond to the optical nodes of the network on which we also account for the cost of the IP/MPLS connected router. We are also given the traffic matrix Λ , where Λ_{sd} corresponds to IP demanded capacity between nodes (s,d) . We are also given the model of the IP/MPLS routers: routers are assumed to be modular, built out of (single or multi) chassis. A chassis provides a number of slots with a nominal transmission speed. Into each router slot, a linecard of the corresponding speed can be installed. Each linecard provides a specified number of ports at a specific speed. In the optical layer, we assume that the transmission capabilities of the transponders, are described in what are called transmission-tuples. Each tuple t represents a specific configuration of the transponder (rate, spectrum) and is related to a specif transmissiion reach, taking into account a model for the optical physical layer (e.g. GN model [15]). The dimensioning solutions are based on pre-calculated optical paths and we assume that a path-transmission tuple (p,t) is fasible if the transmission reach of tuple t is higher than the length of the path p .

To solve the multi-layer survivable network optimization problem we present in the following four ILP formulation, targeting two survivability levels: (i) single optical link, and (ii) single link and IP and optical node failures, and two integration levels: (i) sequential and (ii) joint.

The inputs of the problem are stated in the following:

- The network topology represented by graph $\mathcal{G}(V,L)$.
- The maximum number F of available spectrum slots (of 12.5 GHz)
- The traffic described by the traffic matrix Λ .
- A set T of feasible transmission tuples, which characterize the transmission options of the available transponders (BVTs), with tuple $t=(D_t, R_t, B_t, C_t)$ indicating feasibility of transmission at distance D_t , with rate R_t (Gpbs), using B_t spectrum slots, for the transponder of type (cost) C_t .
- A set of line-cards represented by H , where a line-card for transponder of type C_t is represented by a tuple $h_{C_t}=(N_b, C_b)$, where N_b is the number of transponders C_t that the line-card supports,
- The IP/MPLS router cost, specified by a modular cost model. We assume that an IP/MPLS router consists of line-card chassis of cost $CLCC$, that suport N_{LCC} line-cards each, and fabric card chassis of cost $CFCC$, that suport N_{FCC} line-card chassis.
- The weighting coefficient, W_C , taking values between 0 and 1. Setting $W_C = 1$ minimizes solely the cost while setting $W_C = 0$ minimizes the maximum spectrum used.

A. Sequential (on top) Multi-layer Optical Link Failure resilience (S-OLF)

The failure set for which resilience is provided by this formulation includes all single optical link failures. The proposed resilience scheme consists of two steps. We assume that we are given a dimensioned (both IP and optical layers) network for normal (primary) operation (i.e., assuming no failures). This can be considered as the zero step. Then in the first step, the impact of each optical link failure state on the given IP primary links (tunnels) (step 0) is determined. Finally, in the second step we re-dimension the network for the expected worst-case backup IP traffic.

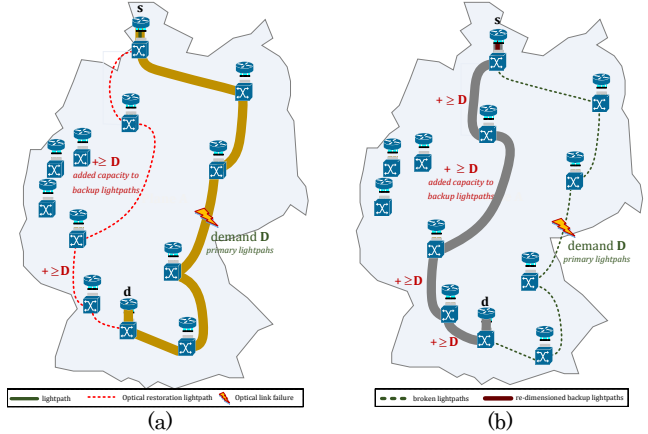

Fig. 3. Sequential multi-layer optical link failure resilience: (a) failure of an optical link along a primary lightpath, (b) setup of the backup path.

Fig. 3 illustrates the case of an optical link failure and the S-OLF survivability mechanism. Upon failure of an optical link along a lightpath (green line - Fig. 3a) that is used by an IP link between two routers (s and d - Fig. 3a), the lightpath is torn down and new lightpath(s) are setup and/or existing lightpath with enough spare capacity are used (grooming). In order to ensure that the lightpaths used for the restoration will have feasible capacity, these backup paths (red line - Fig. 3b) are dimensioned according to the worst case scenario (dotted red line - Fig. 3a) found by the failure analysis. The key to the savings of this survivability scheme is that the additional (backup) resources reserved are not dedicated to addressing any specific failure, but are shared among all possible failures. Compared to an optical layer protection/restoration mechanism, we can exploit grooming at the IP layer to avoid reserving/establishing a new lightpath for each failed one. The drawback of this scheme is that the process is broken into 3 steps and the dimensioning done in the step 0 is independent of failures and thus it is done sub-optimally.

We assume that the network is dimensioned for normal (primary) operation (step 0). As in the dual plane scheme, any multi-layer planning algorithm can be used for this purpose, and in this study we used the joint multi-layer EON planning algorithm of [16]. The algorithm creates the solution by choosing among k (pre-calculated) optical paths P_{ij} between optical nodes ij . Apart from other variables, we assume that the solution includes values for primary IP flow variables f_{sd}^p , which identify the amount of IP traffic of end-nodes s to d that is transferred over optical path p .

We assume as input the dimensioned network, and as so we denote by F_{sd}^p the primary IP flows (considered constants). Then in the first step of the sequential algorithm we capture the impact of optical link failures on IP links that is used in the second step to re-dimension the network. To do so, we define a Boolean constant that determines whether a primary IP flow is affected by an optical link failure. To be more specific, based on the values of the inputs F_{sd}^p , we calculate the constants W_{sd}^l for all demands s, d and all optical links l :

$$W_{sd}^l = \begin{cases} 1, & \text{if } l \in p \text{ and } F_{sd}^p > 0 \\ 0, & \text{otherwise} \end{cases} \quad (1)$$

These constants identify the flows that need to be rerouted, while unaffected traffic is not allowed to be rerouted.

In the second step we re-dimension the network, using the following ILP formulation. For each link l , we pre-calculate the k -shortest paths between optical nodes i and j assuming that l has failed (removing it from the graph) and we denote the corresponding set of paths by P_{ij}^l . Assume that in the zero step we used the algorithm of [14] which is also based on pre-calculated paths denoted by P_{ij} . For each path $p \in P_{ij}$ that includes link l we calculate a new path p^l . Then the set P_{ij}^l is defined as the set P_{ij} where we replace the paths p that use l by the corresponding p^l . Then the set of all paths for failure l is given by $P^l = \cup_{ij} P_{ij}^l$. Note that the primary IP flows F_{sd}^p are assumed to be provided as input.

Variables:

- v_{sd}^{lp} Real variable, representing the backup IP flow from source s to destination d when link l fails that passes over a lightpath that uses path p .
- x_{pt}^l Integer variable, representing the number of lightpaths of path-transmission tuple pairs (p, t) used when link l fails.
- x_{pt} Integer variable, representing the number of lightpaths of path-transmission tuple pairs (p, t) used to recover from any single link failure.
- u_{pfw}^l Boolean variable, equal to 1 if channel (f, w) , i.e. slots $[f, f+w-1]$, is used over path p when link l fails, and 0 otherwise.
- z_{nh} Integer variable, number of line-cards of type h at node n .
- q_n Integer variable, number of line-card chassis at node n .
- o_n Integer variable, number of fiber-card chassis at node n .
- b Integer variable, equal to the maximum indexed spectrum slot.

Objective:

$$\min (W_C \cdot c + (1 - W_C) \cdot b) \quad (2)$$

- Cost calculation constraints:

$$c = \sum_{p \in P} \sum_{t \in T | \exists (p, t)} C_t \cdot x_{pt} + \sum_{n \in V} \sum_{l \in L} C_h \cdot z_{nh} + \sum_{n \in V} C_{LCC} \cdot q_n + \sum_{n \in V} C_{CH} \cdot o_n \quad (3)$$

- IP flow allocation constraints for rerouted and non-rerouted traffic:

$$\forall l \in L, (s, d) \in V^2,$$

If $W_{sd}^l = 1$:

$$\forall n \in V, \sum_{i \in V} \sum_{p \in P_n^i} v_{sd}^{lp} - \sum_{j \in V} \sum_{p \in P_{ij}^l} v_{sd}^{lp} = \begin{cases} \Lambda_{sd}, & n = s \\ -\Lambda_{sd}, & n = d \\ 0, & n \neq s, d \end{cases} \quad (4)$$

else:

$$\forall (i, j) \in V^2, p \in P_{ij} \text{ (with } p^l \in P_{ij}^l \text{ been the backup of } p)$$

$$v_{sd}^{lp^l} = F_{sd}^p \quad (5)$$

- IP flow assignment to lightpaths constraints:

$$\forall l \in L, (i, j) \in V^2, p \in P_{ij}^l$$

$$\sum_{sd \in V^2} v_{sd}^{lp} \leq \sum_{t \in T | \exists (p, t)} (r_t \cdot x_{pt}^l) \quad (6)$$

- Worst case lightpath capacity constraints

$$\forall l \in L, p \in P^l, t \in T | \exists (p, t)$$

$$x_{pt} \geq x_{pt}^l \quad (7)$$

- Data slot assignment constraints:

$$\forall l \in L, p \in P^l, t \in T | \exists (p, t)$$

$$x_{pt}^l = \sum_{f=\{1 \dots F\}} u_{pfw}^l \quad (8)$$

(where B_t is the number of slots required for transmission tuple t)

- Non overlapping slot assignment constraints:

$$\forall l \in L, l' \in L, m \in [1, F]$$

$$\sum_{p \in P^l | l \in p} \sum_{f \in [1, F], w \in \{B_t\}_{t \in T} | m \in [f, f+w-1]} u_{pfw}^l \leq 1 \quad (9)$$

- Maximum slot used constraints:

$$\forall l \in L, l' \in L, f \in [1, F], w \in \{B_t\}_{t \in T}$$

$$b \geq (f + w - 1) \cdot \sum_{p \in P^l | l \in p} u_{pfw}^l \quad (10)$$

- Number of linecards per node constraints:

$$\forall n \in V, h \in H$$

$$z_{nh} \geq \sum_{i, p \in P_n^i} \sum_{t | h \text{ supports } C_t} x_{pt} / N_h \quad (11)$$

- LCC per node constraints:

$$q_n \geq \sum_h z_{nh} / N_{LCC}, \forall n \in V \quad (12)$$

- FCC per node constraints:

$$o_n \geq q_n / N_{CH}, \forall n \in V \quad (13)$$

B. Integrated (joint) Multi-layer Optical link Failure resilience (J-OLF)

This resilience scheme, referred to as J-OLF, adopts a holistic methodology by jointly considering the cost of both network layers (IP/MPLS and optical) and all single optical link failures during the dimensioning process.

Fig. 4 illustrates the case of an optical link failure and the J-OLF survivability mechanism. In Fig. 4a we present some primary lightpaths that are used by IP links between different routers, and we highlight (*green bold line*) the 2 primary lightpaths that are used by the 2 IP links between routers s and d (IP links $s-n$ and $n-d$). Upon failure of the optical link along the primary lightpath that is used by the IP link between routers $s-n$, the lightpath is torn down and a new lightpath is setup. In order to ensure that the restored lightpath will be feasible the backup path (*red bold line* - Fig. 4b) is dimensioned according to the worst case scenario among all link failures. As opposed to the previous case, this analysis is incorporated in a single step. The key to the savings of this survivability scheme is not only the sharing between backup resources, but the joint optimization of primary and backup lightpaths (done sub-optimally in different steps in the previous S-OLF solution). Moreover, we obtain the benefits of doing this in both layers, and thus we exploit the grooming capabilities to avoid reserving/establishing a new lightpath for each failed one as done in optical layer only protection/restoration mechanisms.

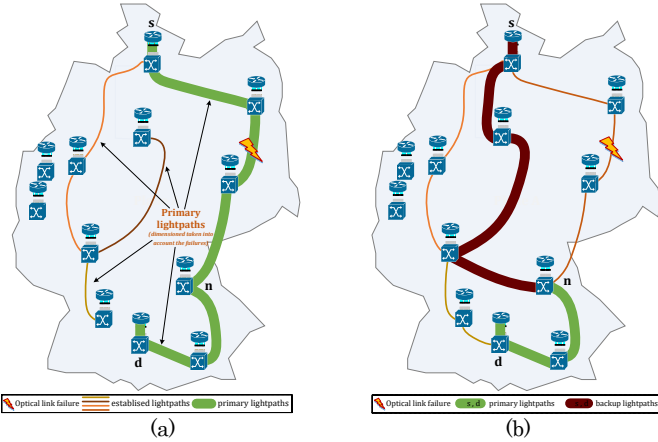

Fig. 4. Integrated multi-layer optical link failure resilience: (a) failure of an optical link along a primary lightpath, (b) setup of the backup path.

Below we outline the ILP model for this technique. The constants/inputs are as in the previous section (Section IV.A) with the addition of constant M , a big number, e.g. $M > \max(\Lambda_{sd})$, that is used to form big-M constraints. The variables v_{sd}^{lp} , x_{pt} , x_{pt}^l , u_{pfs}^l , z_{nh} , q_n , o_n and b are as in Section IV.A. Regarding variables, the key differences are the introduction of two additional types of variables: (i) f_{sd}^p are real variables, representing the primary flow from IP source s to destination d that passes over a lightpath that

uses path p , and (ii) w_{sd}^l are Boolean variables. These were inputs/constants in the previous formulation.

The Objective is as in Eq. (1), while the constraints presented in the previous formulation in Eq. (3), (6), (7), (8), (9), (10), (11), (12) and (13) are identical.

The IP flow allocation constraints for rerouted and non-rerouted traffic (Eq. (4)) are replaced with the following constraints:

- IP flow continuity constraints:

- ❖ Primary IP flow constraints:

$$\forall (s, d) \in V^2, n \in V,$$

$$\sum_{i \in V} \sum_{p \in P_n^i} f_{sd}^p - \sum_{j \in V} \sum_{p \in P_j^i} f_{sd}^p = \begin{cases} \Lambda_{sd}, n = s \\ -\Lambda_{sd}, n = d \\ 0, n \neq s, d \end{cases} \quad (14)$$

- ❖ Backup IP flow constraints:

$$\forall l \in L, (s, d) \in V^2, n \in V,$$

$$\sum_{i \in V} \sum_{p \in P_n^i} v_{sd}^{lp} - \sum_{j \in V} \sum_{p \in P_j^i} v_{sd}^{lp} = \begin{cases} \Lambda_{sd}, n = s \\ -\Lambda_{sd}, n = d \\ 0, n \neq s, d \end{cases} \quad (15)$$

- Disjoint path constraints for failure affected traffic:

$$\forall (s, d) \in V^2, l \in L$$

$$\sum_{ij \in l} \sum_{p \in P_{ij}} f_{sd}^p - M \cdot w_{sd}^l \leq 0 \quad (16)$$

$$\forall (s, d) \in V^2, l \in L, p \in P_{ij} \text{ (with } p^l \in P_{ij}^l \text{ been the backup of } p)$$

$$f_{sd}^p - v_{sd}^{lp^l} - M \cdot w_{sd}^l \leq 0 \quad (17)$$

$$-f_{sd}^p + v_{sd}^{lp^l} - M \cdot w_{sd}^l \leq 0 \quad (18)$$

Equations (14) and (15) are responsible for creating and maintaining the primary and backup IP flows. Equation (16) makes w_{sd}^l to take the value of 1 if a path passes link l and has active primary flow ($f_{sd}^p \geq 0$). Then Eq. (17) and (18) ensure that the primary and backup IP flows are equal when $w_{sd}^l = 0$, that is when the primary flows are not affected by the link failure (avoid re-routing the unaffected traffic). In case that $w_{sd}^l = 1$ Eq. (17) and (18) are deactivated and the backup IP flows are constrained only by the related IP flow constraints – Eq. (15).

C. Sequential (on top) Multi-layer Optical and IP Failure resilience (S-OIF)

This resilience scheme, referred to as S-OIF, is an extension of the sequential technique presented in Section IV.A and expands the failure set under which survivability is provided, by adding to it the optical and IP nodes. In order to survive against every single IP node failure we have to assign a backup IP node for every IP node (in a sense we need to connect each lower level router to two routers in this core domain). Note that some similar is done

in the dual plane approach but in that case the lower level routers connect to routers in the two different network planes, while here both routers belong to the same network.

Similarly to the sequential optical link failure resilience scheme (IV.A), this resilience scheme consists of two steps. We assume that we are given a dimensioned (both layers) network assuming normal operation (no failures), considered as step zero. Then, in the first step, the impact of each considered failure on the IP primary links (tunnels) of the dimensioned network is determined. Finally, in the second step we re-dimension the network for the expected worst-case backup IP traffic.

Fig. 5 illustrates all possible failure cases (IP and optical node, optical link) and the S-OIF survivability mechanism. Each node in the network e.g. take the source node s is assumed to have one backup node, denoted by $B(s)$. Upon any failure that affects the IP flow between e.g. $s-d$, the edge node detects the failure, and switches to a precalculated configuration. The failed lightpath (and maybe others along the end-to-end path) is (are) torn down (*green line* - Fig. 5a) and none, one or more lightpaths are setup and spare capacity of some primary/ established lightpaths is re-used (*red line* - Fig. 5b). The backup traffic can initiate either at the source s or at the backup source $B(s)$ and terminate either at the destination d or the backup destination $B(d)$. In order to ensure that the traffic will be restored, the backup lightpaths are dimensioned according to the worst case traffic scenario (*dotted red line* - Fig. 5a) arising as a result of failure analysis.

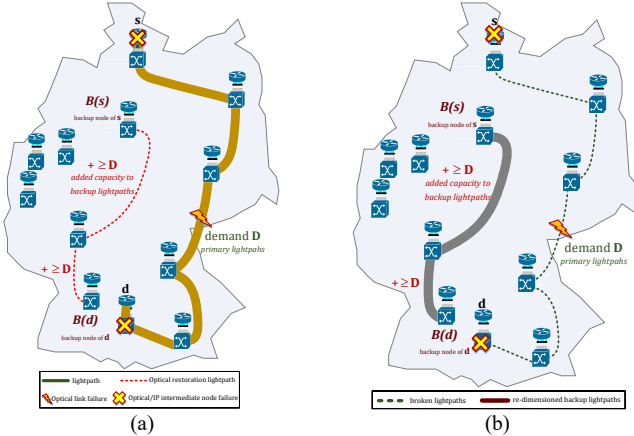

Fig. 5. Sequential multi-layer optical and IP failure resilience: (a) failure (optical link or node failure) along a primary lightpath, (b) setup of the backup path.

Note that the benefits of using this technique are threefold. Firstly, we exploit the sharing between backup resources among different failures, since based on the restoration concept the backup resources are not reserved and dedicated to addressing any specific failure. Secondly, we exploit the grooming options of backup flows affected by the same link failure. Thirdly we exploit the grooming options of primary flows of traffic unaffected by a failing link with backup flows of affected traffic (not done in an optimal way, due to the sequential dimensioning). The second and third gains are enabled by the multi-layer design and would not be possible in single-layer mechanisms.

In addition to the input described in the beginning of this

section we assume that we are also given the following:

- Y : set of candidate failures (could be IP nodes, optical nodes, optical links, and transponders, or all)
- B : the set of backup IP nodes. For each IP node n , a backup IP node is selected (e.g. shortest distance node). The backup of IP node n is denoted by $B(n)$ and the relationship is commutative, meaning that the backup of the backup is the initial node: $B(B(n)) = n$.

We assume again, as in Section IV.A, that we are given a dimensioned network for normal (primary) operation (e.g. using the joint multi-layer EON planning algorithm of [16]). This is referred to as step zero. We again denote by F_{sd}^p the primary IP flows which are passed as input and identify the IP traffic of end-nodes s to d that is transferred over optical path p .

To capture the impact of the failure states on IP links in the first step of the sequential algorithm we precalculate a Boolean constant W_{sd}^y that determines whether the primary IP flow is affected by each failure state ($y \in Y$):

$$\forall y \in Y, (s, d) \in V^2$$

$$W_{sd}^y = \begin{cases} 1, & \text{if any } F_{sd}^p > 0 \text{ is affected by failure } y \\ 0, & \text{otherwise} \end{cases} \quad (19)$$

The second step consists of an ILP formulation, which is outlined in the following. For each failure y , we calculate the k -shortest paths between optical nodes i and j assuming that y has failed (removing it from the graph) and we denote the path set by P_{ij}^y . As in link failures, we take the set of paths P_{ij} that was used in step zero and remove all p that use y and replace them with the related p^y . Then the set of all paths for failure y is given by $P^y = \cup_{ij} P_{ij}^y$.

The ILP has variables x_{pt} , z_{nh} , q_n , o_n and b which are exactly as in Section IV.A, and variables v_{sd}^{yp} , x_{pt}^y and u_{pfw}^y which are similar to the related ones, v_{sd}^{lp} , x_{pt}^l and u_{pfw}^l , but defined here for each failure $y \in Y$ instead of each link $l \in E$.

The Objective is the same as in Eq. (1), the constraints presented in Eq. (3), (11), (12) and (13) are identical, while the constraints in Eq. (6), (7), (8), (9) and (10) are slightly modified to account for the related failures $y \in Y$ instead of the link $l \in E$. The IP flow continuity constraints are replaced by the following:

- IP Flow continuity constraints:

$$\forall y \in Y, (s, d) \in V^2$$

$$\text{if } W_{sd}^y = 1:$$

$$\sum_{j \in V} \sum_{p \in P_{sj}^y} v_{sd}^{yp} + \sum_{j \in V} \sum_{p \in P_{B(s)j}^y} v_{sd}^{yp} = \Lambda_{sd} \quad (20)$$

$$\sum_{i \in V} \sum_{p \in P_{id}^y} v_{sd}^{yp} + \sum_{i \in V} \sum_{p \in P_{iB(d)}^y} v_{sd}^{yp} = \Lambda_{sd} \quad (21)$$

$$\forall n \in V, n \neq s, d, B(s), B(d)$$

$$\sum_{i \in V} \sum_{p \in P_{in}^y} v_{sd}^{yp} = \sum_{j \in V} \sum_{p \in P_{ij}^y} v_{sd}^{yp} \quad (22)$$

else:

$$\forall (i, j) \in V^2, p \in P_{ij}^y \quad v_{sd}^{yp} = F_{sd}^p \quad (23)$$

Equations (20) – (22) correspond to the IP flow continuity constraints of the IP links affected by the failure state y ($W_{sd}^y = 1$). In this case the backup flows are assumed to be able to exit from the source and the backup source (enabling grooming at these nodes) and the same applies for the destination and backup destination. Equation (23) sets the value of the backup flow equal to the primary one, since the primary flow is not affected by the failure state y ($W_{sd}^y = 0$).

D. Integrated (joint) Multi-layer Optical and IP Failure resilience (J-OIF)

This resilience scheme, referred to as J-OIF, considers jointly in the dimensioning process the cost of both network layers (IP/MPLS and optical) and the cost to provide resilience for all possible single optical link/node and IP node failures. It is an extension of the technique presented in section IV.B and expands the failure set under which full survivability is provided, by adding to it optical and IP nodes. It provides the same survivability level with the sequential technique (Section IV.C), integrating the failure analysis with the dimensioning in the same way that the J-LF (Section IV.B) was an extension of S-LF (Section IV.A).

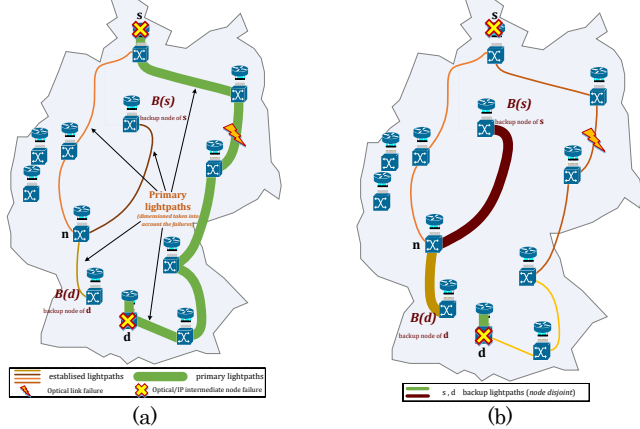

Fig. 6. Integrated multi-layer optical and IP failure resilience: (a) failure (optical link or node) along a primary lightpath, (b) setup of the backup path.

Fig. 6 illustrates all possible failure states and the J-OIF survivability mechanism. We consider as additional input to the design process a set of possible failures and the set of backup IP nodes. In Fig. 6a we highlight (*green bold line*) the primary lightpath that is used by the IP link between routers s and d . Upon a failure that affects this IP link, the lightpath(s) is torn down and a new or more lightpath(s) are setup or existing primary lightpaths with free capacity are used. In the example of Fig. 6a we setup a new lightpath (*bold line* - Fig. 6b) using the backup nodes and a node disjoint lightpath, which is dimensioned according to the worst case traffic scenario. In addition to the benefits of the previous sequential (S-OIF) mechanism, in this joint

mechanism we achieve optimal sharing of primary and backup resources.

The ILP formulation for the J-OIF is outlined in the following.

The input is the same as in Section IV.C, where apart from the input described in the beginning of this Section we have additional input the sets Y and B . We also use a constant M as in Section IV.B for defining “big- M ” constraints. As in Section IV.C, we precalculate the sets P_{ij}^y , P_{ij}^y and P^y . We also have variables v_{sd}^{yp} , x_{pt}^y and $u_{p'fw}^y$, x_{pt} , z_{nh} , q_n , o_n and b as in Section IV.C. In addition to those we have variables f_{sd}^p and w_{sd}^y , which were constants in the Section IV.C, to represent the primary flows and the failure of primary IP links, respectively.

The Objective is the same as in Eq. (1), the constraints presented in the previous formulation in Eq. (3), (11), (12) and (13) are identical, while the constraints in Eq. (6), (7), (8), (9) and (10) are slightly modified to account for the related failures $y \in Y$ instead of the link $l \in E$. The IP flow continuity constraints are replaced by the following:

- IP Flow continuity constraints:

$$\forall (s, d) \in V^2 \quad \begin{aligned} & \text{❖ Primary IP flow constraints:} \\ & \forall n \in V, \sum_{i \in V} \sum_{p \in P_{in}^p} f_{sd}^p - \sum_{j \in V} \sum_{p \in P_{nj}^p} f_{sd}^p = \begin{cases} \Lambda_{sd}, & n = s \\ -\Lambda_{sd}, & n = d \\ 0, & n \neq s, d \end{cases} \quad (24) \end{aligned}$$

- ❖ Backup IP flow constraints:

$$\forall y \in Y \quad \begin{aligned} & \sum_{j \in V} \sum_{p \in P_{sj}^{yp}} v_{sd}^{yp} + \sum_{j \in V} \sum_{p \in P_{B(s)j}^{yp}} v_{sd}^{yp} = \Lambda_{sd} \quad (25) \\ & \sum_{i \in V} \sum_{p \in P_{id}^{yp}} v_{sd}^{yp} + \sum_{i \in V} \sum_{p \in P_{iB(d)}^{yp}} v_{sd}^{yp} = \Lambda_{sd} \quad (26) \end{aligned}$$

$$\forall y \in Y, \forall n \in V, n \neq s, d, B(s), B(d) \quad \sum_{i \in V} \sum_{p \in P_{in}^{yp}} v_{sd}^{yp} = \sum_{j \in V} \sum_{p \in P_{nj}^{yp}} v_{sd}^{yp} \quad (27)$$

- Disjoint optical links and nodes constraints:

$$\forall (s, d) \in V^2, y \in Y \quad \sum_{ij \in V^2} \sum_{p \in P_{ij}^y} f_{sd}^p - M \cdot w_{sd}^y \leq 0 \quad (28)$$

$$\forall (s, d) \in V^2, y \in Y, p \in P_{ij}^y \text{ (with } p^y \in P_{ij}^y \text{ been the backup of } p) \quad f_{sd}^p - v_{sd}^{yp} - M \cdot w_{sd}^y \leq 0 \quad (29)$$

$$-f_{sd}^p + v_{sd}^{yp} - M \cdot w_{sd}^y \leq 0 \quad (30)$$

Equations (24) and (25)-(27) correspond to the primary and backup IP flows continuity constraints. The backup flows can exit from the source or the backup source and enter the destination or the backup destination. Primary and backup flows can be groomed on lightpaths (see Eq. (6)

that is repeated here), and this is done optimally, since both primary and backup IP flows are variables. Eq. (28)-(30) guarantee that the primary and the backup lightpaths are node disjoint when the primary flows are affected by a failure ($w_{sd}^y=1$) or they are the same if primary flow is not affected ($w_{sd}^y=0$). Eq. (28)-(30) are similar to Eq. (16)-(38), which were defined only for single link failures.

TABLE I outlines the main features of the four proposed ILP-based multi-layer restoration techniques. They are classified in terms of the survivability level they offer and their optimization capabilities (which pertain to the related failure consideration level).

As outlined above, in the proposed recovery mechanisms the unaffected traffic is not allowed to be rerouted, so as to maintain the control plane overhead low. This is achieved in the sequential mechanisms S-OLF and S-OIF, by define the Boolean constants W_{sd}^l and W_{sd}^y that determine whether a primary IP flow is affected by an optical link failure (S-OLF), or by the failure states (S-OIF), respectively. We then distinguish between affected and unaffected traffic: for S-OIF constraints (4) pertain to affected and (5) pertain to unaffected traffic (which sets the backup flows to equal the primary). Similarly, for S-OIF, constraints Eq. (20)-(22) pertain to affected, while constraints Eq. (23) to unaffected traffic. The same idea is applied in the joint J-OLF and J-OIF approaches, the only difference to the sequential being that we use variables W_{sd}^l and W_{sd}^y , instead of the related constants. Alternatively, we could enable the rerouting of the unaffected connections, but penalize it so that it would be done only in cases that would improve substantially the performance. This would complicate further the ILP model and is left for future extensions.

V. ILLUSTRATIVE RESULTS

In this section we evaluate the performance of the resilience techniques presented in Section IV. In particular we distinguished the following two scenarios:

- The single optical link failure survivability scenario, where we compare the techniques presented in section IV.A (denoted as *S-OLF*) and in section IV.B (denoted as *J-OLF*) to the optical 1+1 protection scheme [17].
- The single node (*optical and IP*) and optical link failure survivability scenario, where we compare the techniques presented in section IV.C (denoted as *S-OIF*) and in section IV.D (denoted as *J-OIF*) to the traditional dual plane (1+1 IP protection) scheme.

The techniques used in each survivability scenario offer the same level of survivability, but exploit resource sharing at different degrees. The reference 1+1 optical protection and dual plane, dedicate additional resources for each failure. The sequential techniques (S-OLF and S-OIF) exploit in an optimal way the sharing of the backup resources to survive of different failures (performing optimal multi-layer restoration) and sub-optimally the sharing of the primary and backup resources (since primary and backup resources are allocated sequentially). The joint

techniques (J-OLF and J-OIF) are even more efficient and exploit the optimal sharing of primary and backup resources.

TABLE I
Survivability Techniques: Overview

Survivability Technique	Survives against		Select primary & backup source/destination nodes	Optimal Sharing between backup resources	Joint optimization of primary and backup resources
	Optical failures	IP failures			
<i>S-OLF</i>	●	✗	✗	●	✗
<i>J-OLF</i>	●	✗	✗	●	●
<i>S-OIF</i>	●	●	●	●	✗
<i>J-OIF</i>	●	●	●	●	●

In our simulations we used two reference network topologies with different characteristics in terms of number of nodes, link lengths and load: the Deutsche Telekom (DTAG - TABLE II) and the Telefónica (TID - TABLE II) topologies, so that the results obtained are representative of real networks. For these networks we also used realistic traffic matrices. The traffic matrices of the DT and TID networks used in our simulations were based on input by the related operators reported in the framework of the IDEALIST project [18] for past years. Assuming a uniform 35% increase per year we created the traffic matrices for the DT and TID networks for year 2016 with total load equal to 6388.23 Gbit/s and 2773.26 Gbit/s, respectively. We also projected the traffic of these networks for 10 years, with a step of 2 years assuming again 35% uniform increase per year. These traffic matrices, corresponding to different years/traffic were used for planning the whole survivable network from scratch, without taking into account the solutions for previous years.

We assumed that each link of the reference networks is a single fiber with 320 spectrum slots available of 12.5 GHz width.

TABLE II
DT AND TID NATIONAL BACKBONE NETWORKS

DT						TID					
Operator	Location		Segment Covered			Operator	Location		Segment Covered		
DT	Germany		Core			TID	Spain		Core		
Nodes	Nodal Degree		Link length (km)			Nodes	Nodal Degree		Link length (km)		
	average	max	Links	average	max		average	max	Links	average	max
12	3	5	40 <i>bidirectional</i>	243	459	30	3.7	5	56 <i>bidirectional</i>	148	313

A difference between the 2 topologies is that in DT all optical nodes are assumed to be interconnected with IP routers, while in the Telefónica there are several optical transit nodes, not connected to IP routers with no traffic terminating/initiating at those nodes.

Following the IDEALIST cost model [18], the reference cost unit (c.u.) that we use is the 100 Gb/s coherent transponder. As nowadays the state of the art in the transponder technology is now coherent 100 Gb/s, the cost unit is defined as the cost of such a 100 Gb/s device. For the optical nodes we assumed *colorless directionless and contentionless* (CDC) ROADMs that use EDFAs, WSS1x9 (fiber interfaces), WSS1x20 (add/drop function), with

relative costs 0.06 c.u., 0.32 c.u. and 0.48 c.u., respectively. In our cost calculations we also took into account the cost of inline EDFAs. We assumed spans of 80 Km length, and span was followed by an inline EDFA that fully compensated the loss. The transmissions tuples (reach, rate, spectrum and cost) of the bandwidth variable transponders (BVT) and the cost of the BVT are presented in TABLE III and are based on the IDEALIST project. The adopted cost model for the IP routers takes into account the number of the line-cards used, the number of line-cards fitted in a shelf (N_{LCC}), also called a line-card chassis (LCC) with cost $C_{LCC}=6.02$ c.u., and the number of LCCs (N_{FCC}) fitted in a fiber-card chassis (FCC), which costs $C_{FCC}=9.1$ c.u.. Core routers are capable of a minimum of 16 (one shelf - LCC) to a maximum of 1152 (72 shelves - LCCs) slots for hosting line-cards. Since we assumed a single BVT model, we also assumed a single linecard type that drives one BVT ($N_{BVT}=1$) with cost $C_{BVT}=2.56$ c.u.

TABLE III
BANDWIDTH VARIABLE TRANSPONDERS

Capacity (Gb/s)	Reach (km)	Data slots	Capacity (Gb/s)	Reach (km)	Data slots
40	4000	5	100	3000	4
	3000	4		2500	3
	2500	3		1900	2
200	2200	6	400	750	9
	1900	5		600	7
	750	4		500	5
cost of BVT (cost units)				1.76	

Since we are solving an offline problem, the running time is not considered a major issue, but in order to avoid searching for intractable solutions, we set a time limit in the execution of the ILP model. In our simulations we set the execution time limit to 5 hours. For low traffic the optimality bound returned by CPLEX solver for the joint J-OLF was lower than 3% for light traffic, while for heavy traffic it was about 7%. The optimality bounds were improved by about 1-2% (depending on load) for the sequential S-OLF.

A. Capital Expenditure

In this section we compare the different survivability techniques with respect to the cost (CapEx) for the two reference networks (Fig. 7 and Fig. 8). Note that at each survivability scenario the compared techniques provide the same level of survivability.

In figures Fig. 7a and Fig. 8a we compare the performance of planning techniques that survive against single optical link failures (Sections IV.A and IV.B). We use an optical layer dedicated protection scheme (*optical 1+1*) as benchmark for the comparison.

In both examined networks under every traffic load, the multi-layer techniques are shown to exhibit lower CapEx. This is expected since the optical 1+1 protection scheme places additional resources dedicated for each failure, and is not able to exploit the grooming capabilities (since it only considers the optical layer).

The joint technique (J-OLF) performs similarly to the sequential (S-OLF), slightly outperforming it under every traffic condition. The joint technique incorporates the failure analysis in a single dimensioning step, offering high capacity efficiency and maximal sharing of primary and

backup resources. Through Fig. 7a and Fig. 8a we are able to confirm the superiority of both proposed multi-layer techniques and the integrated design strategy (*J-OLF*). Note that the reference 1+1 protection scheme results in almost double of the optical network cost. The cost of the IP layer is substantial compared to the cost of the optical network, a fact that limits the overall savings that can be achieved.

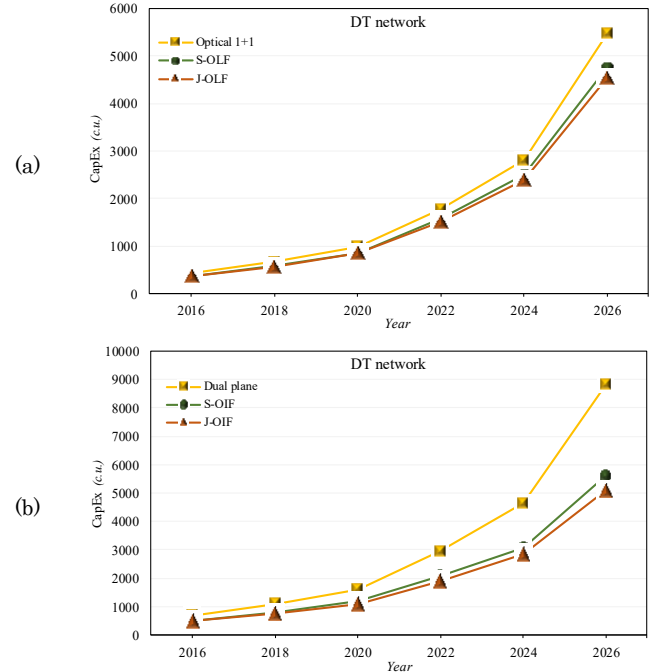

Fig. 7 Capital Expenditure for the DT network: (a) optical layer survivability (b) multi-layer survivability.

In figures Fig. 7b and Fig. 8b we examine the performance of proposed techniques that provide higher level of resilience (Sections IV.C and IV.D), and can survive (optical and IP) node and optical link failures. As benchmark for comparison with the proposed multi-layer techniques we use the dual plane approach. In both examined networks the multi-layer techniques clearly outperform the dual plane technique. In both network topologies we achieve savings that range between 26% for light traffic loads and 42% for heavy traffic loads. Following the traditional dual plane approach of having protection at the IP layer, results in comparably bad utilization of the network equipment. The proposed techniques avoid over-provisioning by exploiting grooming and sharing of resources between primary and backups to effectively utilize these resources.

Figures Fig. 8b and Fig. 8b show that the joint (J-OIF) technique outperforms the sequential (S-OIF) technique. Clearly, dimensioning the network and considering all failure states as done by the J-OIF is quite more efficient than re-dimensioning the backup paths of the network on top of an already dimensioned network for normal operation. As the load increases the efficiency of the joint resilience technique becomes more evident.

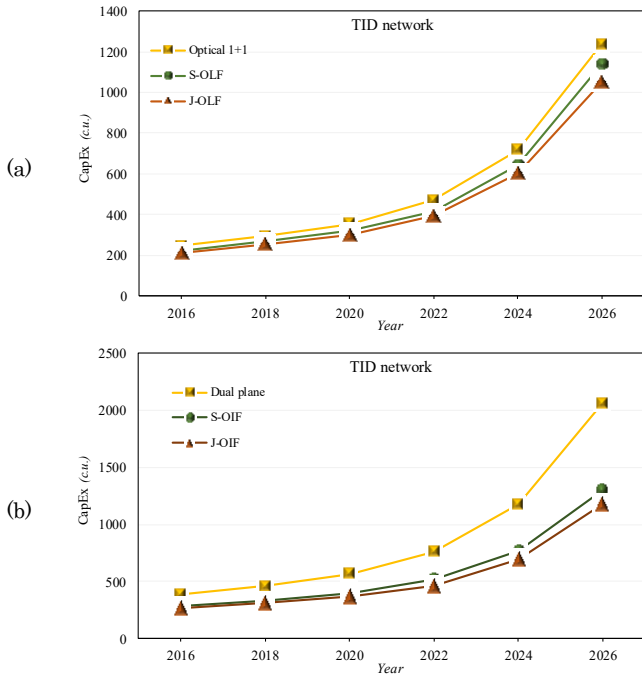

Fig. 8 Capital Expenditure for the Telefónica network: (a) optical layer survivability, (b) multi-layer survivability.

Note that in the above results we did not assume any decrease in prices of the components over time. Our study is comparative and would not benefit from such models. Moreover, it stands to reason to assume that the considered components will follow almost similar depreciation trends, and therefore the price changes through time will not affect our comparison.

B. Maximum Spectrum used

We now present the results obtained regarding spectrum utilization for the two reference networks (TABLE II). The optical 1+1 scheme, due to the bad utilization of transponders on the optical layer exhibits in all cases, the worst performance. The proposed resilience techniques exploit the grooming capabilities to reduce the number of transponders used in the network achieving lowest spectrum in every traffic scenario. From Fig. 9, it becomes evident that the dual plane approach clearly outperforms every other resilience technique regardless the integration level that offers. This can be easily explained by the fact that the dual plane strategy creates two variants of the network, where each of these variants is designed for normal operation. Note that we depict here the spectrum used in each variant and not the summation of the two. This is valid, considering that we have two network variants and thus we have doubled the available spectrum. The main incentive for using the multi-layer survivability techniques lies in the significant cost savings that such techniques can achieve, but clearly there is a trade-off between spectrum utilization and cost. Including failure analysis in the design process introduces additional traffic load that occurs in different failure states. This additional traffic is the main reason that the proposed resilience techniques exhibit worse spectrum utilization.

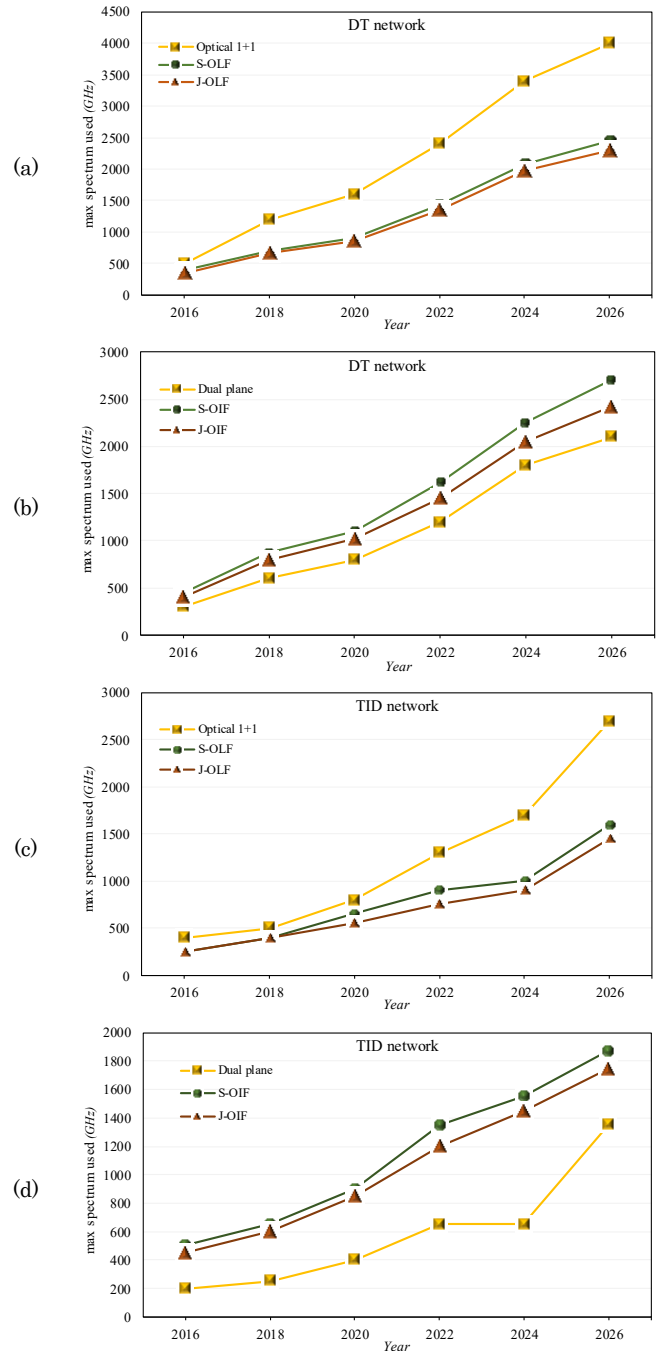

Fig. 9 Maximum spectrum used for the DT network topology: (a) optical layer survivability, (b) multi-layer survivability and Telefónica network topology: (c) optical layer survivability, (d) multi-layer survivability.

C. Reduction of IP ports

In this section we report on the reduction on the number of IP core-facing ports we can achieve through the multi-layer techniques for the two topologies of our study. For clarity, we normalized the results to the dual plane approach for each case. The number of IP ports used in the network is a significant metric, which can provide insight about the cost efficiency of each technique. This can be explained by the fact that the number of transponders and the modules of IP chassis used are directly correlated to the

number of core-facing IP ports. It is evident that by using multi-layer survivable techniques we can achieve an important reduction on the number of the router interfaces for all years/traffic load examined. Reductions are high for the first examined year and increase for later years, reach up to 50% for the last examined year.

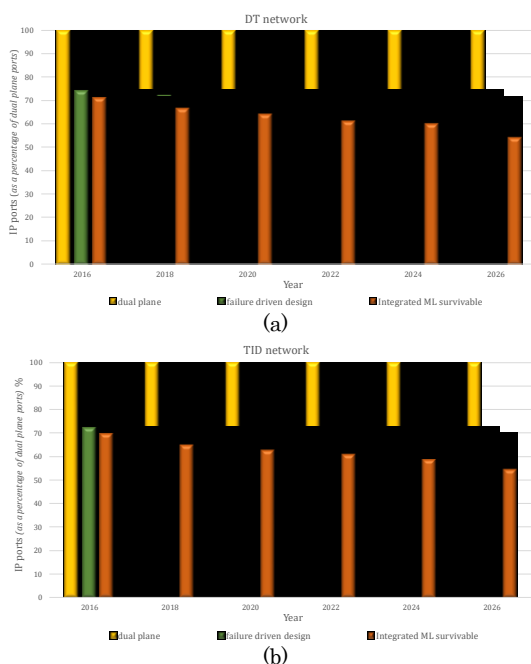

Fig. 10 IP ports reduction through multi-layer survivability algorithms for: (a) the DT network, (b) the Telefónica network.

VI. CONCLUSION

In this paper we focused on the inherent inefficiencies of the single-layer resilience strategies in IP over elastic optical networks (EON). We proposed proactive restoration techniques which involve both the optical network and its IP edges to achieve efficient resource usage and reduce the cost. We presented ILP formulations to provide survivability against (i) any single optical link, and (ii) any single optical link or node, or IP node failure. We investigated the benefits of multi-layer network planning and the integration of failure analysis in this process. We conducted extensive experiments to evaluate the performance of the proposed multi-layer network restoration techniques, using realistic traffic, network topologies and cost models. Our results indicate that significant cost savings can be obtained when we dimension the IP over EON considering multi-layer resilience, as opposed to the case where the traffic is protected at the IP layer or at the optical layer only. We also verified that dimensioning jointly the network for normal and failure operation leads to a more efficient resources usage by allowing maximal sharing of the primary and backup resources.

REFERENCES

[1] M. Jinno, H. Takara, B. Kozicki, Y. Tsukishima, Y. Sone and S. Matsuoka, "Spectrum-efficient and scalable elastic optical path network: architecture, benefits, and enabling

technologies," in *IEEE Communications Magazine*, vol. 47, no. 11, pp. 66-73, November 2009.

[2] O. Gerstel, C. Filsfil, T. Telkamp, M. Gunkel, M. Horneffer, V. Lopez, A. Mayoral, "Multi-layer capacity planning for IP-optical networks", *IEEE Communications Magazine*, Vol. 52(1), pp. 44-51, 2014.

[3] M. Gunkel, "Multi-layer restoration - the impact on the optical layer," *OFC, 2014*, vol., no., pp.1-3, 9-13 March 2014.

[4] R. Shenai, C. Maciocco, M. Mishra, K. Sivalingam, "Threshold based selective link restoration for optical WDM mesh networks", *Fourth International Workshop on Design of Reliable Communication Networks*, pp. 31-38, 2003.

[5] S.-I. Kim, S. Lumetta, "Restoration of all-optical mesh networks with path-based flooding", *Journal of Lightwave Technology*, Vol. 21(11), pp. 2605-2616, 2003.

[6] A. Giorgetti, F. Paolucci, F. Cugini, P. Castoldi, "Dynamic restoration with GMPLS and SDN control plane in elastic optical networks", *Journal of Optical Communications and Networking*, Vol. 7(2), pp. A174-A182, 2015.

[7] M. Dallaglio, A. Giorgetti, N. Sambo, F. Cugini and P. Castoldi, "Provisioning and restoration with sliceability in GMPLS-based elastic optical networks [Invited]," in *IEEE/OSA Journal of Optical Communications and Networking*, vol. 7, no. 2, pp. A309-A317, February 1 2015.

[8] F. Muñoz, V. López, Ó. González de Dios, and J. P. Fernández-Palacios, "Multi-layer restoration in hierarchical IP/MPLS over WSON networks," in *Networks and Optical Communications (NOC)*, June 2012.

[9] M. Ruiz, O. Pedrola, L. Velasco, D. Careglio, J. Fernández-Palacios and G. Junyent, "Survivable IP/MPLS-Over-WSON Multilayer Network Optimization," in *IEEE/OSA Journal of Optical Communications and Networking*, vol. 3, no. 8, pp. 629-640, August 2011.

[10] A. Mayoral, V. López, O. Gerstel, E. Palkopoulou, Ó G. de Dios and J. P. Fernández-Palacios, "Minimizing resource protection in IP over WDM networks: Multi-layer shared backup router [invited]," in *IEEE/OSA Journal of Optical Communications and Networking*, vol. 7, no. 3, pp. A440-A446, March 2015.

[11] E. Palkopoulou, O. Gerstel, I. Stiakogiannakis, T. Telkamp, "Impact of IP layer routing policy on multilayer design", *Journal of Optical Communications and Networking*, 7(3), pp. A396-A402, 2015.

[12] M. Gunkel, A. Autenrieth, M. Neugirg, J.-P. Elbers, "Advanced Multilayer Resilience Scheme with Optical Restoration for IP-over-DWDM Core Networks", *4th International Congress on Ultra Modern Telecommunications and Control Systems and Workshops*, pp. 657-662 2012.

[13] J. J. Pedreno-Manresa, J. L. Izquierdo-Zaragoza and P. Pavon-Marino, "Joint fault tolerant and latency-aware design of multilayer optical networks," *2016 International Conference on Optical Network Design and Modeling (ONDM)*, Cartagena, 2016, pp. 1-6.

[14] D. Amar, E. L. Rouzic, N. Brochier, C. Lepers, "Multilayer Restoration in Elastic Optical Networks", *International Conference on Optical Network Design and Modeling*, 2015.

[15] P. Poggiolini, "The GN Model of Non-Linear Propagation in Uncompensated Coherent Optical Systems," in *Journal of Lightwave Technology*, vol. 30, no. 24, pp. 3857-3879, Dec.15, 2012.

[16] P. Papanikolaou, K. Christodoulopoulos and E. Varvarigos, "Multilayer flex-grid network planning," *Optical Network Design and Modeling (ONDM)*, 2015 International Conference on, Pisa, 2015, pp. 151-156.

[17] P. Papanikolaou, K. Christodoulopoulos, and E. Varvarigos, "Joint Multilayer Planning of Survivable Elastic Optical Networks," in *Optical Fiber Communication Conference, OSA Technical Digest (online) (Optical Society of America, 2016)*, paper M2K.3.P.

[18] IDEALIST EU project, <http://www.ict-idealist.eu/>.