



HELLENIC REPUBLIC
MINISTRY OF DEVELOPMENT
GENERAL SECRETARIAT FOR RESEARCH AND INNOVATION
HELLENIC FOUNDATION FOR RESEARCH AND INNOVATION



H.F.R.I.
Hellenic Foundation for
Research & Innovation

DETERMINED will lay the foundations for deterministic, low-latency, and secure communication infrastructures, enabling time-critical IoT and 5G/6G applications through advanced networking, edge–cloud orchestration, and post-quantum security technologies.

AT A GLANCE

Project title:

DetermIneD

Designing and Configuring Deterministic Network Domains for Industry 4.0 and Centralized 5G/6G Virtual Functions

Principal Investigator

Konstantinos Christodoulopoulos, University of Athens, Greece

Duration:

11/2023 – 11/2025

Programme:

Hellenic Foundation for Research & Innovation Greece 2.0 NATIONAL RECOVERY AND RESILIENCE PLAN “BASIC RESEARCH FINANCING” (Horizontal support for all Sciences) ID 16618 – Subproject 1 (MIS: 5163923)

Further information:

http://users.uoa.gr/~kchristodou/determined_w ebsite.html

Context and motivation

Future IoT and 5G/6G applications demand **ultra-low latency, deterministic performance, and strong security guarantees** across highly distributed infrastructures. Traditional cloud-centric deployment models are unable to consistently meet these requirements due to variable latency, limited control over jitter, and increasing security threats posed by quantum computing. At the same time, the migration toward **cloud-native microservice architectures** and the proliferation of edge and far-edge resources introduce new complexity in resource allocation, orchestration, and network control.

Challenge

Modern communication infrastructures must simultaneously ensure **deterministic networking, secure key distribution, and efficient placement of microservices** across the edge–cloud continuum. Key challenges include controlling latency and jitter in Ethernet-based networks, securely distributing cryptographic keys in the post-quantum era, and orchestrating heterogeneous compute and network resources while respecting application-level requirements. Existing approaches often optimize from a single operator-centric perspective, overlooking fine-grained application intents and deterministic constraints.

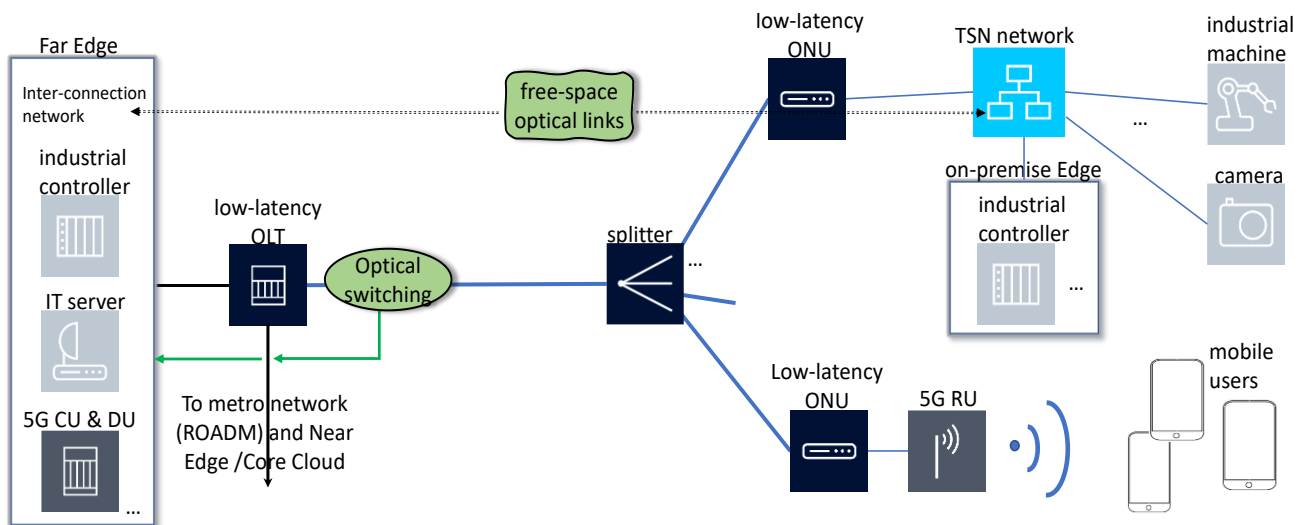

DETERMINED reference architecture

Solution

DETERMINED addresses these challenges through an integrated framework combining **deterministic networking, secure communication, and intent-driven resource orchestration**. The project evaluates IEEE Time-Sensitive Networking (TSN) mechanisms—such as Credit-Based Shaper (CBS), Frame Preemption (FP), and Time-Aware Shaper (TAS)—to enable predictable latency and bounded jitter in Ethernet networks. In parallel, it investigates **Quantum Key Distribution (QKD)** architectures, including Relayed and Switched QKD, to support secure symmetric key distribution resilient to quantum attacks.

To efficiently deploy cloud-native IoT and 5G/6G microservices, DETERMINED introduces **lexicographic, intent-based resource allocation mechanisms** that prioritize application requirements across near-edge, far-edge, and core cloud infrastructures. Software-Defined Networking (SDN) and NETCONF-based management are leveraged to automate configuration and control of deterministic network functions.

Impact

DETERMINED contributes toward **trustworthy, low-latency, and deterministic digital infrastructures** suitable for future industrial, IoT, and mobile network deployments. Its outcomes support improved predictability in time-critical applications, enhanced resilience against emerging security threats, and more flexible orchestration of distributed resources. The project advances both scientific understanding and practical methodologies in deterministic networking, post-quantum security, and edge–cloud resource management.